

# FLUX

30 X 60MM METAL TILE

*karim*

## TILE SPECIFICATIONS

WIDTH	30 mm
LENGTH	60 mm
THICKNESS	1.6 mm solid metal
GROUT LINE	1.32 mm

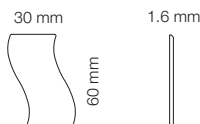

- Designed by Karim Rashid exclusively for ALLOY. One of eight innovative designs that play with the idea of pattern, grid, and repetition. A contemporary statement for interior and exterior applications.
- Immaculately designed and manufactured from solid, high quality metal to create an unsurpassed metal tile finish to last a lifetime. Will not dent, crack or de-laminate.
- Face mounted for ease of installation, to protect the metal tile face and keep tiles in formation. The ALLOY developed system includes 2 layers of protective adhesive tape and film on the tile face. No backing mesh is used. See the ALLOY Installation Guide for details.
- Designed and made in Australia for consistent high quality.
- Finishing pieces available to ensure the perfect installation where a full tile will not fit. ALLOY tiles are made from solid metal and have a specially chamfered edge, therefore tiles should not be cut on site.
- Grout - not required unless installed in a wet area. It is **essential** that an un-sanded, non-grit grout is used, we recommend Laticrete 600/1600 series.
- Adhesive - we recommend ALLOY One Pack Mastic (AOPM), available in black or white, specifically developed for ALLOY Tiles.
- Tile samples and AOPM can be ordered through [alloydesign.com.au](http://alloydesign.com.au)
- As a specialised metal tile, we recommend ALLOY tiles are installed by a highly experienced, professional tiler.

## TILE SHEET

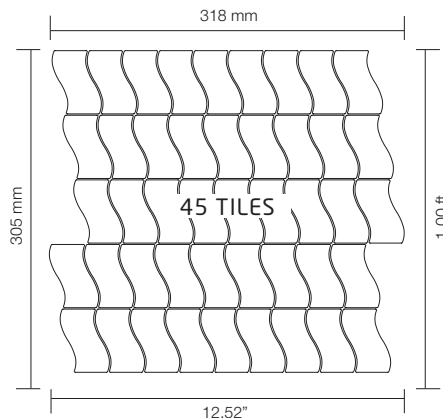

11.63 tile sheets per m<sup>2</sup>

## FINISHING PIECE

Available on request

\*NOT TO SCALE.

**ALLOY**