

# LINEAR

100 X 10MM METAL TILE

## TILE SPECIFICATIONS

WIDTH 100mm  
LENGTH 10mm  
THICKNESS 1.6mm solid metal  
GROUT LINE 1.32mm



- The authentic ALLOY solid metal mosaic tile, developed in 1998 for interior and exterior applications.
- Immaculately designed and manufactured from solid, high quality metal to create an unsurpassed metal tile finish to last a lifetime. Will not dent, crack or de-laminate.
- Face mounted for ease of installation, to protect the metal tile face and keep tiles in formation. The ALLOY developed system includes 2 layers of protective adhesive tape and film on the tile face. No backing mesh is used. See the ALLOY Installation Guide for details.
- Designed and made in Australia for consistent high quality.
- Finishing pieces available to ensure the perfect installation where a full tile will not fit. ALLOY tiles are made from solid metal and have a specially chamfered edge, therefore tiles should not be cut on site.
- Grout - not required unless installed in a wet area. It is **essential** that an un-sanded, non-grit grout is used, we recommend Laticrete 600/1600 series.
- Adhesive - we recommend ALLOY One Pack Mastic (AOPM), available in black or white, specifically developed for ALLOY Tiles.
- Tile samples and AOPM can be ordered through [alloydesign.com.au](http://alloydesign.com.au)
- As a specialised metal tile, we recommend ALLOY tiles are installed by a highly experienced, professional tiler.

## TILE SHEET

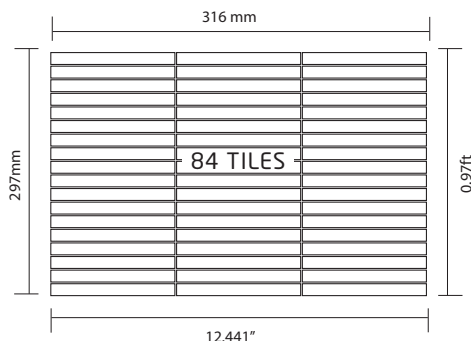

10.66 tile sheets per m<sup>2</sup>

## FINISHING PIECES

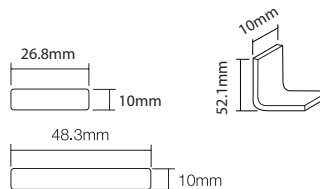

\*NOT TO SCALE.

 **ALLOY**